

# DTC-400 XL

DRILL TAP MACHINING CENTER

**AMS**<sup>®</sup>  
In Pursuit of Excellence

High Productivity... Now Affordable...



## Standard Features

Chip to chip time - 1.8 sec  
16 Tool Pocket Tilting type ATC  
10000 RPM Direct drive  
BT-30/BBT-30  
7.5 / 5.5 kW Spindle power  
60 / 60 / 48 m/min rapid traverse  
High Speed Rigid tapping  
Fanuc OiMF Package

## Optional Features

12000 RPM Direct drive  
Automatic pallet changer - linear / Rotary  
Auto door  
Coolant through spindle  
Siemens / Mitsubishi package  
Chip conveyor  
Tooled up & Automation solutions

# DTC-400 XL

## DRILL TAP MACHINING CENTER

**AMS**<sup>®</sup>  
In Pursuit of Excellence

### Technical Specifications

<b>Travels</b>		
X	mm	500
Y	mm	400
Z	mm	320
Dist. from spindle Face to table top	mm	110-430
<b>Table</b>		
Table size	mm	650 x 400
Max. load on table	Kg	250
Table height from floor	mm	835
<b>Spindle</b>		
Tool shank type		BT-30/BBT-30
Spindle speed - Std.	rpm	100-10000
- Opt.	rpm	120-12000
Spindle power - Std.	kW	7.5/5.5
(15 min/Continuous)		
<b>Feed</b>		
Cutting feed	m/min	1 - 10
Rapid traverse	m/min	60 / 60 / 48
<b>Automatic tool changer</b>		
No. of tools		16
Tool Dia. Max.	mm	80
Tool weight Max.	kg	3
Tool Length Max.	mm	250
Tool Change system		DISC ARMLESS
Chip to chip time	sec.	1.8
<b>Accuracy(As per ISO 230-2)</b>		
Positioning accuracy	mm	0.010
Repeatability	mm	±0.003
<b>Control System</b>		
Fanuc	std.	0iMF
<b>Installation data</b>		
Machine Width	mm	1700
Machine Depth	mm	2800
Machine Height	mm	2500
Machine Weight – Net	kg	3200

\*All specifications are subject to change without prior notice

### Special features:

Pocket tilting type ATC
Wide door opening
Easy loading
Compact machine
Totally enclosed guarding
Liner pallet changer - 600 x 385mm (Optional)
Rotary pallet changer - 600 x 400mm (Optional)

### Machine Layout

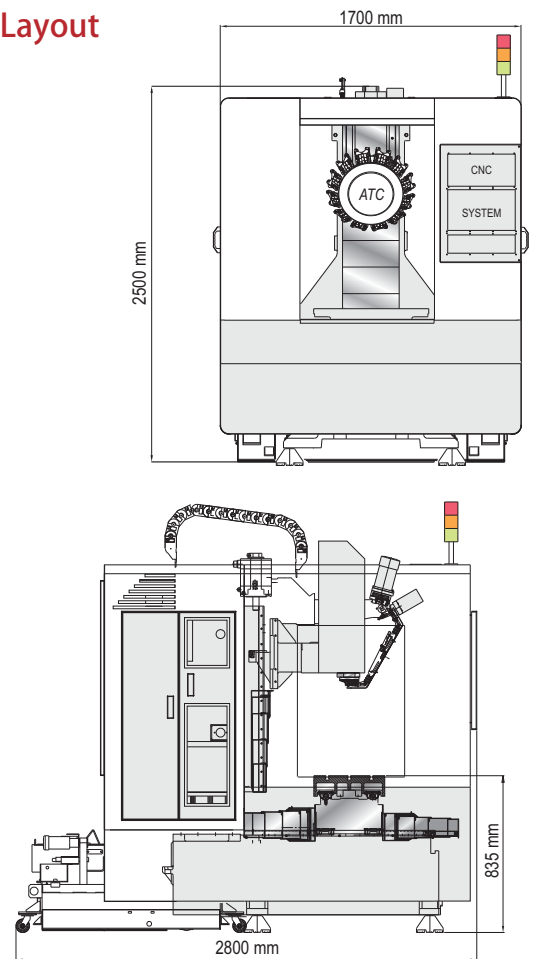

## AMS<sup>®</sup> ACE MANUFACTURING SYSTEMS LTD.

In Pursuit of Excellence

Plot No. 467 - 469, 4th Phase, Peenya Industrial Area, BANGALORE - 560 058. INDIA.

Tel : +91-80-28360508 / 41828100, Fax: +91-80-28362791, E-mail : helpdesk@amslindia.co.in Website : www.amsl.in

### INDIA-Marketed & Serviced by **Micromatic**

Ahmedabad +91 99242 89892; Ambattur +91 98407 85521; Aurangabad +91 240 2552309, 6511434; Bangalore +91 80 40200555; Belgaum +91 99800 02597; Bommasandra +91 80 27834836;  
Chakan +91 2135 322002; Chennai +91 44 40440700; Coimbatore +91 422 4506183, 6588595; Delhi +91 11 22414232/ 42448095; Faridabad +91 129 4047000; Gurgaon +91 124 4745500 / 4745500;  
Hyderabad +91 40 23070496; Pithampur +91 73899 39190, 73899 39191; Jamshedpur +91 657 6539931; Kolhapur +91 230 2460444, 2460123; Kolkata +91 33 23648781/82/83 /64578825;  
Ludhiana +91 97791 28296; Mumbai +91 22 26861009/1976/7271/7272; Nasik +91 253 6610254; Pune +91 20 40712111/27479661/9662; Rajkot +91 281 6548369/2923048/3012775; Ranipet +91 4172 272732;  
Rohtak +91 99966 91055; Rudrapur +91 95570 30224, +91 97201 06532; Tambaram +91 44 22265531; Thane +91 22 25889006; Trichy +91 9843265434, 9786016543

### INTERNATIONAL

SAEILO, Germany (Dealer)  
T: +49-6446-9247-0 (#700)  
E: cs@saeilo.de

CERI, France (Dealer)  
T: +33 (0)2 32 40 27 85  
E: asabia@ceri-mo.fr

MICROMATIC MACHINE TOOLS (SHANGHAI) CO. LTD. China  
T: +86 (21) 5866 5031/32  
E: raghuramachandran@acemicromatic.com

URAL TOOL PUMORI, Russia (Dealer)  
T: (+90) 332 342 52 55  
E: oleg@uipumori.ru

BAE YOUNG MACHINE (Dealer),  
South Korea  
T: (+82) 10 4789 1235  
E: ryan.lee.hs@gmail.com

Visit us @[www.amsl.in](http://www.amsl.in)

